

Data sheet

Temperature controller AVTB (PN 16)

Description



AVTB is self-acting temperature controller used to control the water temperature in hot water tanks, heat exchangers, oil preheaters, etc. Controller closes on rising temperature.

The controller has a control valve, thermostatic actuator and handle for temperature setting. Thermostatic actuator consist of a bellows, capillary tube and sensor.

Main data:

- DN 15, 20, 25
- k_{VS} 1.9, 3.4, 5.5 m³/h
- PN 16
- Setting range: 0...30 °C / 20...60 °C / 30...100 °C
- Temperature:
 - Circulation water / glycolic water up to 30%: -25 ... +130 °C
- Connections:
 - Int. thread
 - Ext. thread (weld-on and ext. thread tailpieces)
- Flow or return mounting, depending on sensor type.

Ordering

AVTB Controller

Picture	DN	Setting range (°C)	k_{VS} (m ³ /h)	Max. sensor temp. (°C)	Internal thread		External thread	
					Connection ISO 7/1	Code No. ¹⁾	Connection ISO 228/1	Code No. ¹⁾
	15	0 ... 30	1.9	55	R _p 1/2	003N2232 ⁴⁾	G 3/4 A	003N5101 ⁴⁾
		20 ... 60		90		003N8229 ²⁾		003N5114 ²⁾
		30 ... 100		130		003N8141 ³⁾		003N5141 ³⁾
	20	0 ... 30	3.4	55	R _p 3/4	003N3232 ⁴⁾	G 1 A	003N5102 ⁴⁾
		20 ... 60		90		003N8230 ²⁾		003N5115 ²⁾
		30 ... 100		130		003N8142 ³⁾		003N5142 ³⁾
	25	0 ... 30	5.5	55	R _p 1	003N4232 ⁴⁾	G 1 1/4 A	003N5103 ⁴⁾
		20 ... 60		90		003N8253 ²⁾		003N5116 ²⁾
		30 ... 100		130		003N8143 ³⁾		003N5143 ³⁾

Capillary tube length: 2 m.

- ¹⁾ Complete controller including sensor stuffing box. The immersion pocket is an accessory.
- ²⁾ Including small sensor Ø 9.5 × 180. The sensor is to be mounted where the system temperature is warmer than the temperature in the valve housing. Insulation disk is factory mounted on the controller.
- ³⁾ Including small sensor Ø 9.5 × 150. Capillary tube length 2.3 m.
- ⁴⁾ Including sensor Ø 18 × 210; available on request

Example:

Temperature controller, DN 15, k_{VS} 1.9, PN 16, setting range 30 ... 100 °C, t_{max} 130 °C, ext. thread

- 1× AVTB DN 15 Controller
Code No: **003N5141**

Option:

- 1× Imm. pocket, brass
Code No: **013U0290**
- 1× Weld-on taipieces
Code No: **003H6908**

Accessories

Picture	Type designations	DN	Connection	Code No.
	Weld-on taipieces	15	-	003H6908
		20		003H6909
		25		003H6910
	External thread taipieces	15	Con. ext. thread acc. to EN 10226-1	R 1/2" 003H6902
		20		R 3/4" 003H6903
		25		R 1" 003H6904
	Immersion pocket	R _p 1/2 × M14 × 1 mm, brass 182 mm, without sens.stuff. box		013U0290
		R _p 1/2 × M18 × 1,5 mm, st. steel 182 mm, with sens.stuff. box		003N0196
		R _p 3/4 × M22 × 1 mm, brass 220 mm, with sens.stuff. box		003N0050
		R _p 3/4 × M22 × 1 mm, st. steel 220 mm, with sens.stuff. box		003N0192
	Insulation disk ¹⁾			003N4022

¹⁾ For details see "Installation positions" section

Ordering (continuous)
Service kits

Picture	Type designation	for	Code No.	
	<i>Repair set</i> Two diaphragms, two O-rings, one rubber cone, one tube of grease and eight valve cover screws	DN 15	003N4006	
		DN 20	003N4007	
		DN 25	003N4008	
		Thermostatic actuator 0 ... 30 °C, sensor Ø 18 × 210, 2m		003N0075
		Thermostatic actuator 20 ... 60 °C, sensor Ø 9.5 × 180, 2m		003N0130
		Thermostatic actuator 30 ... 100 °C, sensor Ø 9.5 × 150, 2.3m		003N0131
		Housing of sensor stuffing box, R ½ × M14 × 1 mm, rubber EPDM Ø 12.6 × 4 × 6 mm		013U8102 ¹⁾

¹⁾ For thermostatic actuators 20 ... 60 °C and 30 ... 100 °C; code includes housing and gasket of sensor stuffing box

Technical data

Nominal diameter	DN	15	20	25
k_{VS} value	m ³ /h	1.9	3.4	5.5
Cavitation factor z		0.4		
Nominal pressure	PN	16		
Max. differential pressure	bar	10		
Medium		Circulation water / glycolic water up to 30%		
Medium pH		Min. 7, max. 10		
Medium temperature	°C	-25 ... +130		
Connections	valve	Internal and external thread		
	tailpieces	Weld-on and external thread		
Materials				
Valve body	internal thread	MS 58, hot-pressed, DIN 17660, W.No. 2.0402, CuZn40Pb2		
	external thread	Dezincing-free brass, BS 2872/CZ132		
Valve seat		Cr Ni steel, DIN 17440, W.No. 1.4301		
Valve cone		NBR-rubber		
Spindle		Dezincing-free brass, BS 2872/CZ132		
Other metal parts		Dezincing-free brass, BS 2874/CZ132		
Diaphragms, O-rings		EPDM-rubber		
Temperature sensor		Copper		
Sensor charge	0 ... 30 °C	R 152 A, C2H4F2		
	20 ... 60 °C	Butane R600, C4H10		
	30 ... 100 °C	Carbon dioxide, CO ₂		

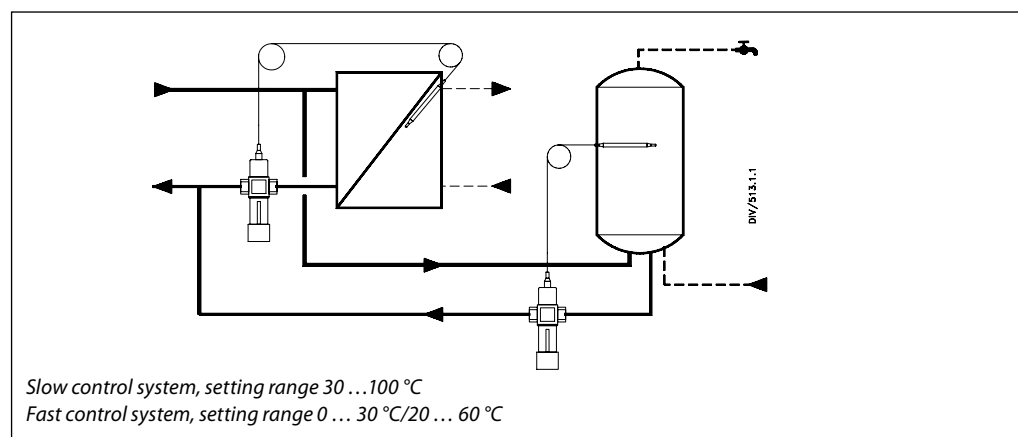
Application principle

Installation positions

Temperature controller

The controller can be installed in any position, with flow in the direction of the cast-in arrow.

AVTB 0 ... 30 and 30 ...100 can be installed either in flow or in return line.

AVTB 20 ... 60 must always be installed in the return line (sensor warmer than valve).

With AVTB 30 ... 100, if temperature variations of more than 20 °C occur at the valve, insulation disk (003N4022) must be installed between thermostatic actuator and valve body.

If AVTB 20 ... 60 has been installed in the return line from a service water heat exchanger (where for certain periods the return temperature approaches the sensor temperature) the installation of insulation disk is recommended (003N4022). **Insulation disk is factory mounted on the product.**

Temperature sensor

Sensor Ø 18 × 210 mm ²⁾
(AVTB 0 ... 30 °C)

Sensor Ø 9.5 × 180 mm ¹⁾
(AVTB 20 ... 60 °C)

Sensor Ø 9.5 × 150 mm ²⁾
(AVTB 30 ... 100 °C)

¹⁾ The sensor is to be mounted where the system temperature is warmer than the temperature in the valve body
²⁾ The sensor can be mounted where the system temperature is either warmer or colder than the temperature in the valve body

Sizing

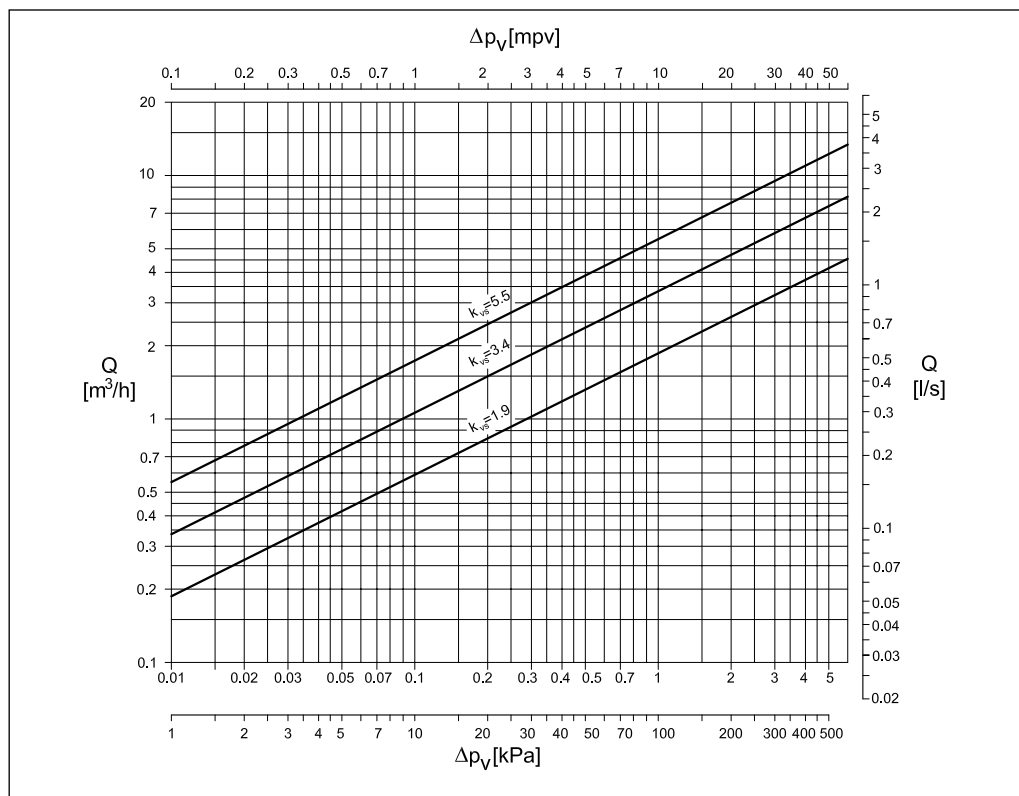

Sizing (continuous)

Example

Hot water temperature control in hot water tanks.

Primary medium:	Water
Given:	
Load:	31 kW (26500 kcal/h)
Primary temperature drop Δt :	20 K
Differential pressure Δp across the valve:	1.7 bar
Max. hot water temperature:	55 °C
Water volume Q:	$\frac{31 \times 0.86}{20} = 1.3 \text{ m}^3/\text{h}$

Required:
The correct valve size

$$k_v = \frac{Q}{\sqrt{\Delta p}} = \frac{1.3}{\sqrt{1.7}} = 1.0 \text{ m}^3/\text{h}$$

Temperature range and P-band

Calculated k_v value is 1 m³/h. From this value on the k_v scale in the AVTB diagram, take a line horizontally to intersect the columns for recommended sizing range. Select the smallest possible valve, here an AVTB 15. A temperature range of 30 ... 100 °C can be assumed as suitable for this example. The P-band (X_p) and final temperature range can also be read from the AVTB diagram. The required closing temperature can be read from the scale for the valve selected. However, there are two temperature ranges that meet the requirement for a closing temperature of 55 °C. X_p is 9 K for the range 30 ... 100 °C, which means that the controller will yield the calculated capacity at a sensor temperature of 55 °C minus 9 K = 46 °C. For the range 20 ... 60 °C X_p = 4 K. This means that the controller will yield the calculated capacity at 55 °C minus 4 K = 51 °C.

To ensure the most stable control an AVTB 15 with a range 30 ... 100 °C should be chosen. The water in the hot water tank will reach the closing temperature (55 °C) only when there has been no hot water demand for some time.

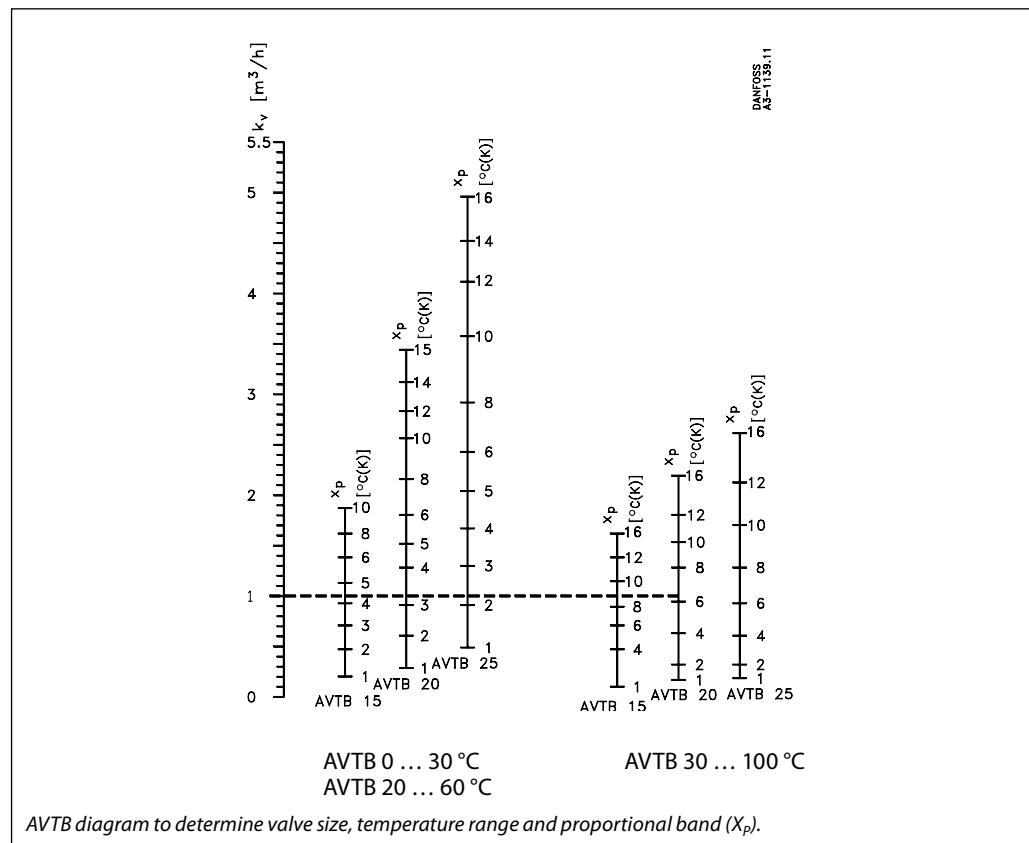

Note: The values stated are mean values

Design

- 1. Handle for temperature setting
- 2. Spring housing
- 3. Setting spring
- 4. O-ring
- 5. Diaphragm
- 6. Spindle
- 7. Valve body
- 8. Valve cone
- 9. Bellows
- 10. Bellows stop
- 11. Pressure stem
- 12. Temperature sensor
- 13. Sensor stuffing box
- 14. Housing of sensor stuffing box
- 15. Gasket of sensor stuffing box
- 16. Sealing bolt of sensor stuffing box

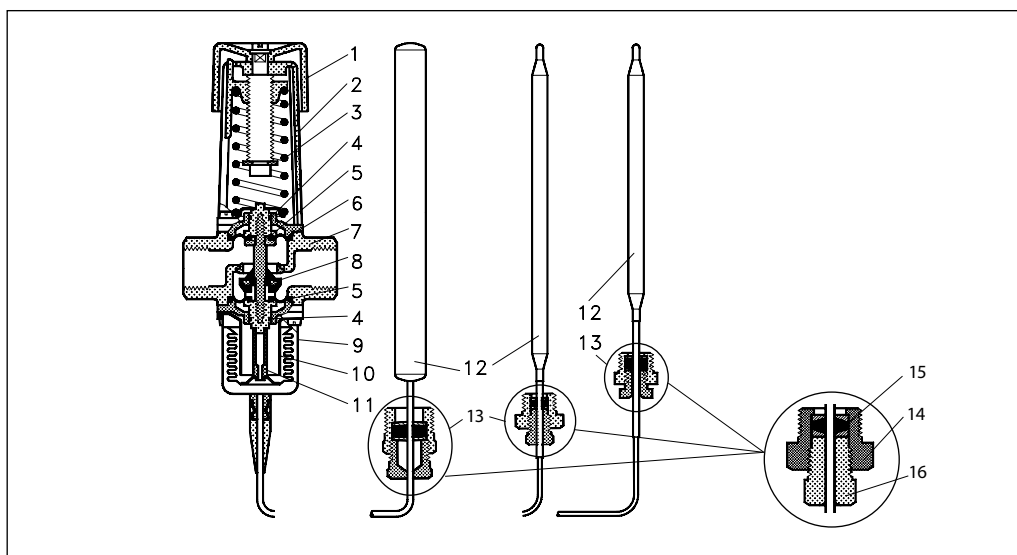

Settings

Temperature setting

Relation between scale numbers 1-5 and the closing temperature.

The values given are approximate.

Scale setting	1	2	3	4	5	
Closing temperature (0 ... 30 °C)		0	3	15	23	30 °C
(20 ... 60 °C)	20	35	50	60	70	
(30 ... 100 °C)	30	35	55	75	95	120

Dimensions

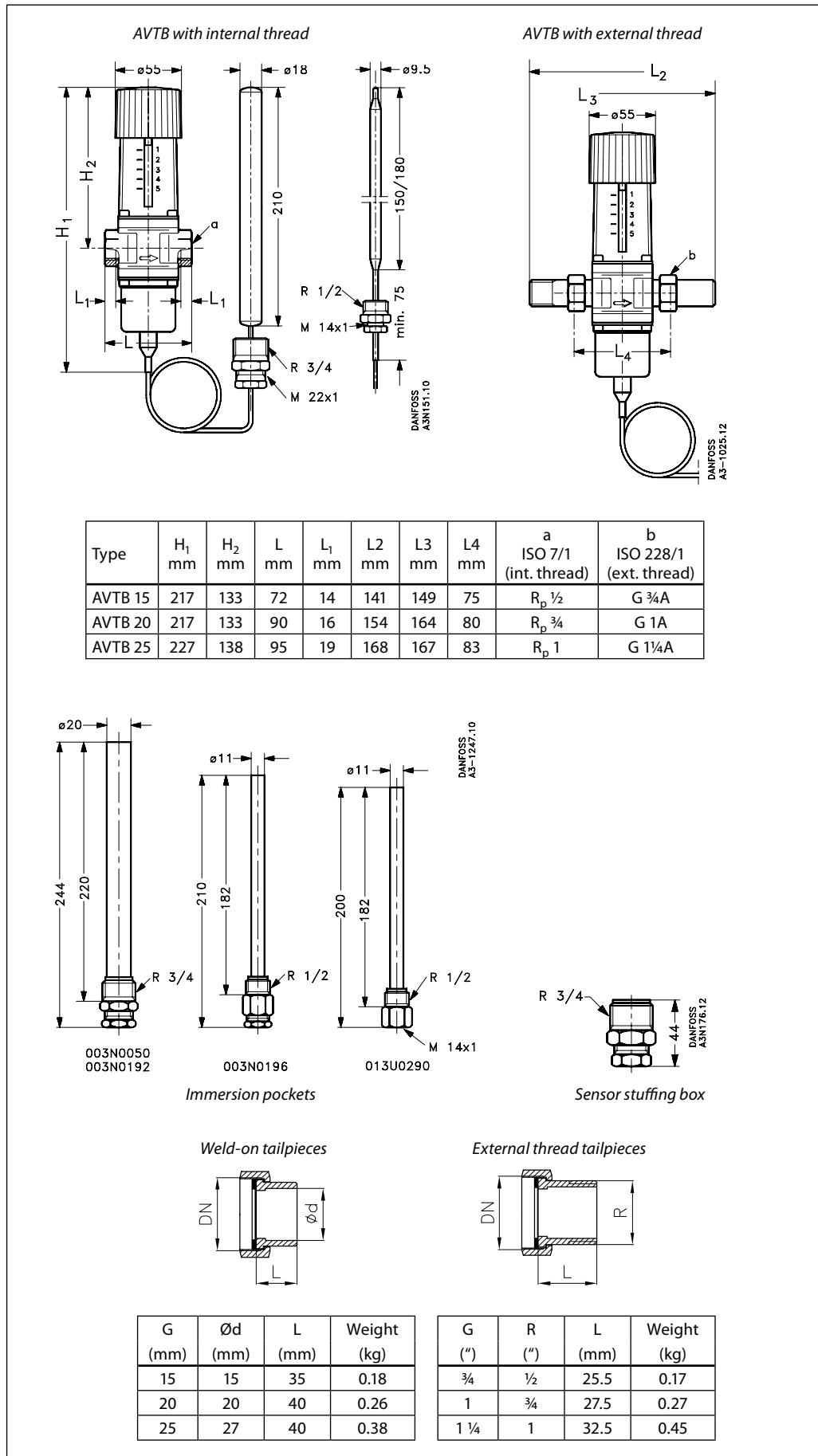

Danfoss can accept no responsibility for possible errors in catalogues, brochures and other printed material. Danfoss reserves the right to alter its products without notice. This also applies to products already on order provided that such alterations can be made without subsequential changes being necessary in specifications already agreed. All trademarks in this material are property of the respective companies. Danfoss and the Danfoss logotype are trademarks of Danfoss A/S. All rights reserved.

